

**Thermal Fogger**  
**K-10-STD<sup>1)</sup>**  
**K-10-O<sup>2)</sup>**  
**portable**



**Technical data:**

Weight empty:	8,5 kg
Size (length x breadth x height):	129 x 29 x 36 cm
Capacity of solution tank:	9 litres
Capacity of fuel tank:	2 litres
Cubic capacity of engine:	300 cm <sup>3</sup>
Max. performance of engine:	17,5 kW (24,1 hp, 15.300 kcal/h)
Max. fuel consumption:	1,9 l/h
Automatic ignition:	Electronic ignition coil fed by 4 x dry batteries = 6V
Starting device:	Manual start
Flow rate:	10 - 35 l/h (according to nozzle size used)
Standard flow rate:	12 l/h
Droplet size spectrum	< 25 µm (oil)
(depending on oil viscosity	< 60 µm (oil/water)
and nozzle size used):	< 150 µm (water)

**Fogging technique and application:**

Thermal fogging is the generation of ultra-fine droplets in a range of 1-50 µm using thermo-pneumatic energy. Liquid substances are vaporized in the unit and form ultra-fine aerosols by condensing on contact with cool ambient air. Thermal fogging is used for any pest control task where active substances should be uniformly distributed even in inaccessible places, without leaving undesirable residues.

The fogging technique is the solution for treating large areas and spaces with a minimum quantity of pesticide solution, less operational work and with little harm to the environment (less residues, no penetration into the ground), e.g. in the field of public health, stock protection, plant protection, disinfection, decontamination, deodorization and cinema effects.

<sup>1)</sup> **Standard-units** are designed to fog water-based, non-flammable fogging solutions and suspensions.

<sup>2)</sup> **O-units** are designed to fog inflammable and non-flammable fogging solutions but not suspensions.

# K-10 Features



- pulse-jet engine without movable parts allows unlimited operation.
- 9 litres solution tank, easily detachable, made of heavy duty polyethylene, transparent with litre scale.
- Double stainless steel-cooling jacket/diffuser with front cooling air intake, additional sound absorption and effective heat control.
- pulsFOG fingertip quick-start-system through patented direct fuel injection and automatic ignition.
- For safety-reasons: non-pressurized fuel tank.
- Most metal parts made of stainless steel.
- Manual fog control valve combined with automatic cut-off device (optional).
- Simple and straightforward design enables the user to carry out repair work himself.

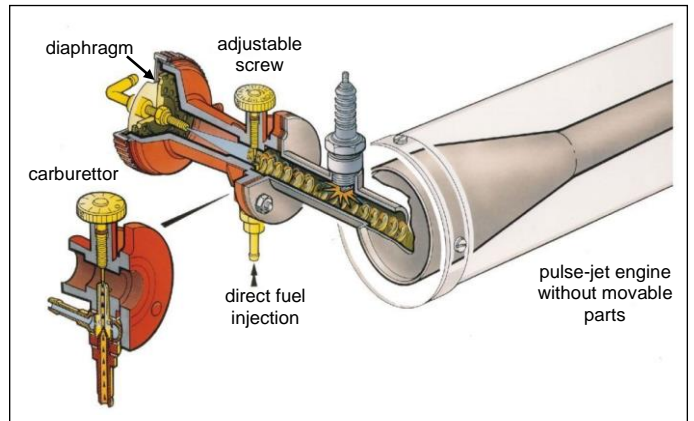

## Automatic cut-off device (optional):

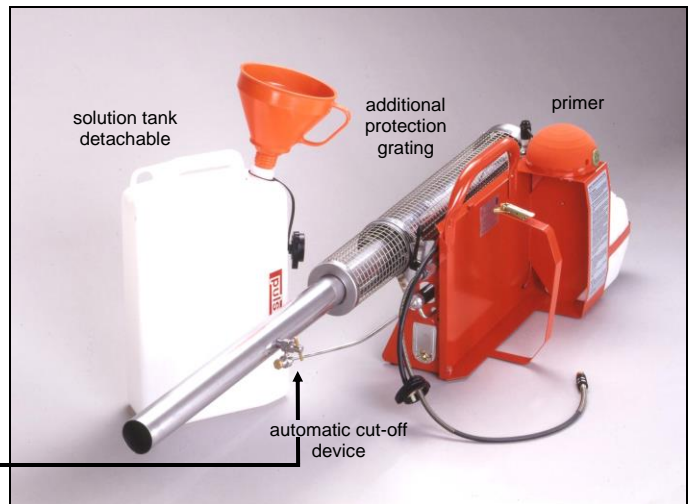
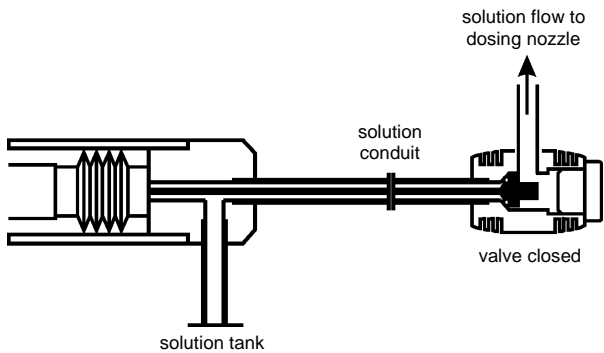

## Finger-tip-start by a simple finger press

- Open adjustable screw on carburettor.
- Push down the primer for immediate fuel injection and engine start.



a)

b)

## Standard accessories:

Fuel pitcher, solution funnel, spare parts bag with membranes and sealing rings, cleaning brush and ear protectors

## Optional accessories:

Air agitator, automatic cut-off device, additional protection grating, dosing nozzles of different sizes, protective suit, respiratory mask with filter A<sub>2</sub> B<sub>2</sub>-P<sub>3</sub>

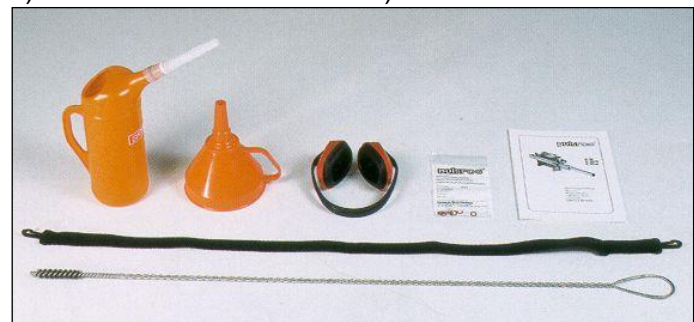

Subject to technical changes 10/2011



## pulsFOG Dr. Stahl & Sohn GmbH

Abigstraße 8 • D-88662 Überlingen • Tel. (0) 7551 / 9261-0 • Fax (0) 7551 / 926161  
E-Mail: info@pulsfog.com • Internet: http://www.pulsfog.com